



SERVING THE FOOD INDUSTRY SINCE 1951

## Square Glass Countertop Refrigerated Showcases

Item: 47107	47278	47279
MODEL: RS-CN-0120-5	RS-CN-0160-5	RS-CN-0202-5



47107 - 28 Inch



47278 - 35 Inch



47279 - 48 Inch

**Attractively  
designed to boost  
impulse sales**

Keeping your good freshness at  
safe temperatures



Telephone: 1-800-465-0234

Fax: (905) 607-0234

Email: sales@omcan.com

Website: www.omcan.com



Authorized Dealer

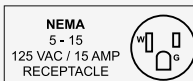

# 28" – 120 L Refrigerated Showcase

ITEM: 47107



## SPECIFICATIONS

Item	47107
Model	RS-CN-0120-5
Electrical	110V / 60Hz / 1Ph
Power Input	160 W
Rated Current	2.7 Amps
Capacity	120L / 4.2 cu. ft.
Shelf Capacity	33 lbs/ 15 kg
Rack Size	13.2" x 25" / 335 x 636 mm 14.4" x 25" / 367 x 636 mm
Max. Ambient Temperature	30°C / 86°F
Temperature Range	0 - 12°C / 32 - 53.6°F
Refrigerant	R290
Net Weight	125.7 lbs / 57 kg
Gross Weight	132.3 lbs / 60 kg
Net Dimensions (DWH)	27.6" x 22.4" x 27" 702 x 568 x 686 mm
Gross Dimensions (DWH)	30.4" x 24.7" x 29" 773 x 627 x 735 mm



## TECHNICAL DRAWINGS & DIMENSIONS

\*measurements in diagrams are in mm

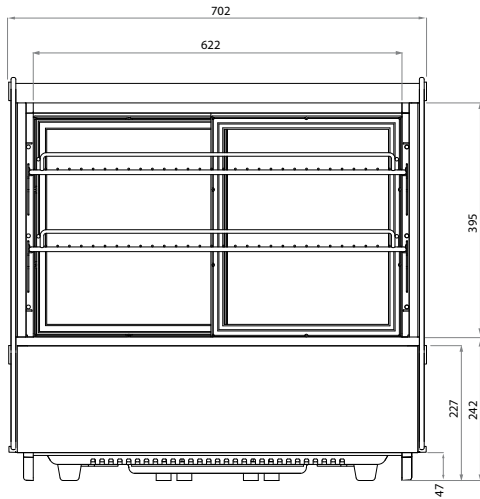

FRONT VIEW

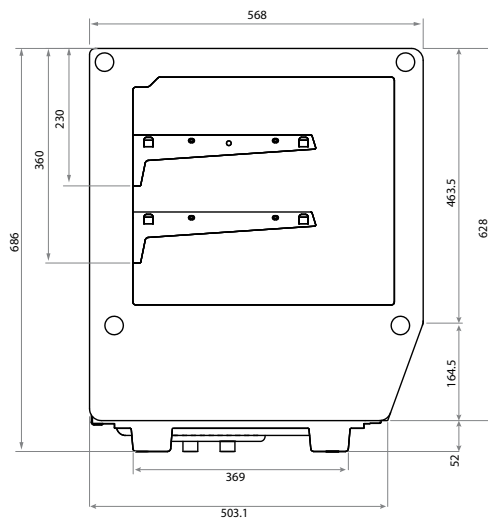

SIDE VIEW

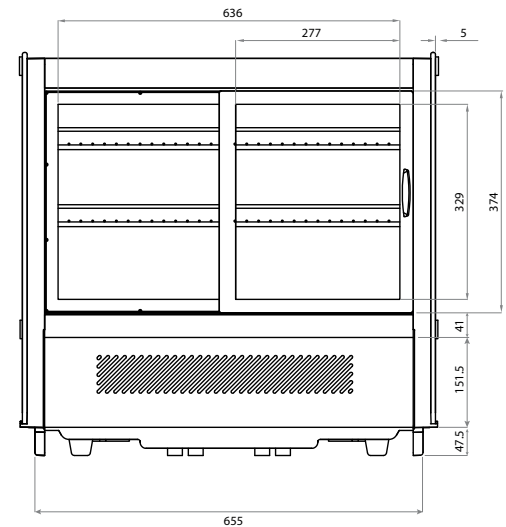

BACK VIEW



NEMA  
5 - 15  
125 VAC / 15 AMP  
RECEPTACLE



# 35" – 160L Refrigerated Showcase

ITEM: 47278



## SPECIFICATIONS

Item	47278
Model	RS-CN-0160-5
Electrical	110V / 60Hz / 1Ph
Power Input	160 W
Rated Current	3 Amps
Capacity	160L / 5.65 cu. ft.
Shelf Capacity	33 lbs / 15kg
Rack Size	13.2" x 32" / 335 x 813 mm 14.4" x 32" / 367 x 813 mm
Max. Ambient Temperature	30°C / 86°F
Temperature Range	0 - 12 °C / 32 - 53.6 °F
Refrigerant	R290
Net Weight	145.5 lbs / 66 kg
Gross Weight	153.2 lbs / 69.5 kg
Net Dimensions (DWH)	34.6" x 22.4" x 27" 880 x 568 x 686 mm
Gross Dimensions (DWH)	37.4" x 24.7" x 29" 951 x 627 x 735 mm



## TECHNICAL DRAWINGS & DIMENSIONS

\*measurements in diagrams are in mm

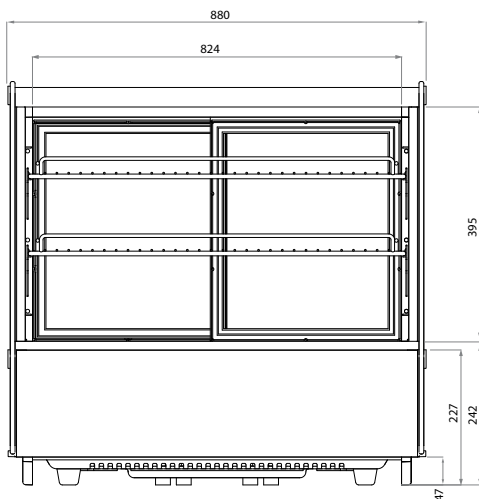

FRONT VIEW

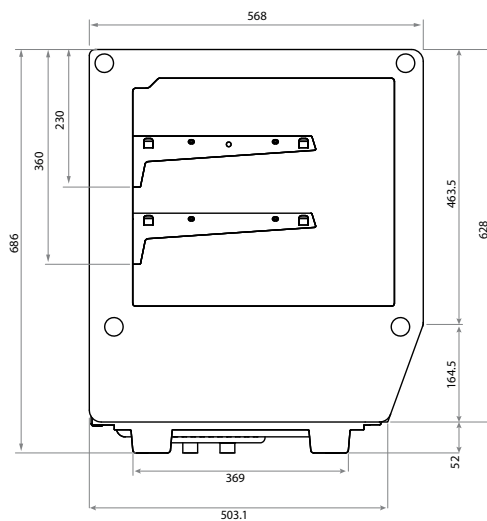

SIDE VIEW

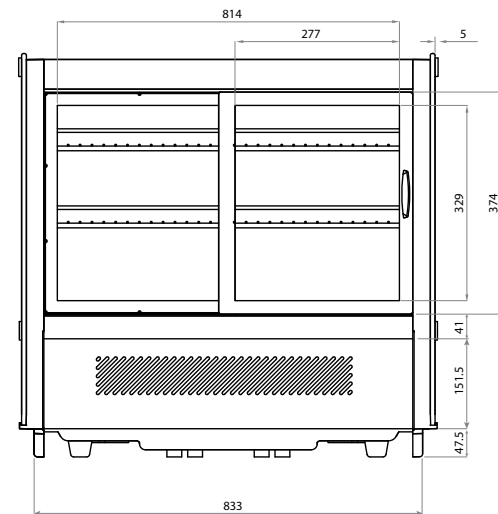

BACK VIEW



NEMA  
5 - 15  
125 VAC / 15 AMP  
RECEPTACLE



# 48" – 202 L Refrigerated Showcase

ITEM: 47279



## TECHNICAL DRAWINGS & DIMENSIONS

\*measurements in diagrams are in mm

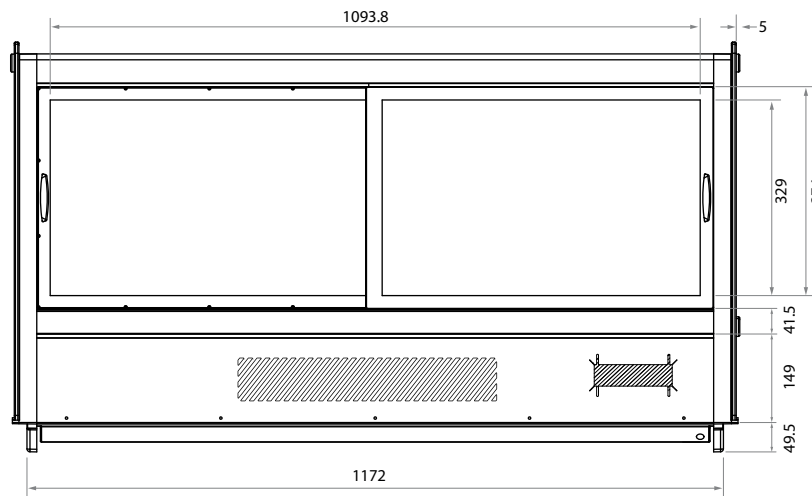
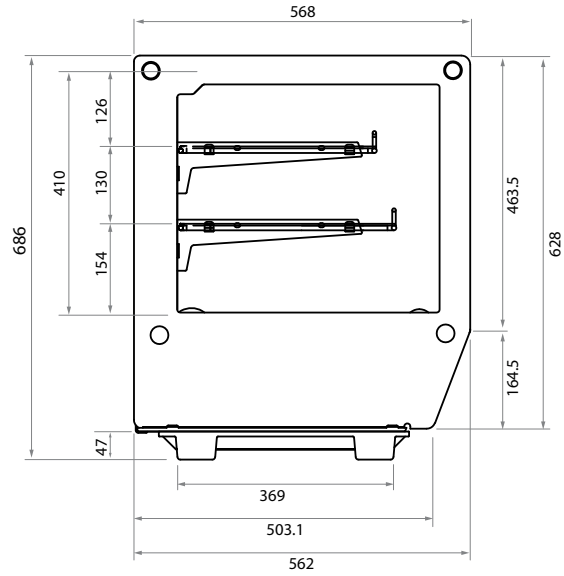
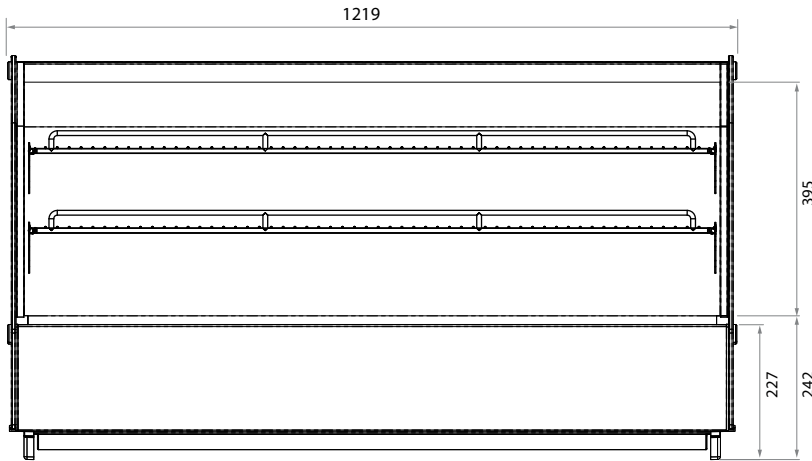

## SPECIFICATIONS

Item	47279
Model	RS-CN-0202-5
Electrical	110V / 60Hz / 1Ph
Power Input	360 W
Rated Current	3.9 Amps
Capacity	202L / 7.13 cu. ft.
Shelf Capacity	44 lbs / 20 kg
Rack Size	13.2" x 45.5" / 335 x 1156 mm 14.4" x 45.5" / 367 x 1156 mm
Max. Ambient Temperature	30°C / 86°F
Temperature Range	0 - 12°C / 32 - 53.6°F
Refrigerant	R290
Net Weight	198.4 lbs / 90 kg
Gross Weight	203.9 lbs / 92.5 kg
Net Dimensions (DWH)	48" x 22.4" x 27" 1219 x 568 x 686 mm
Gross Dimensions (DWH)	50.8" x 24.7" x 29" 1290 x 627 x 735 mm



NEMA  
5-15  
125 VAC / 15 AMP  
RECEPTACLE

